

South Carolina Ways & Means Committee

JANUARY 15, 2025

PATRIOTS POINT
NAVAL & MARITIME
MUSEUM



Home of the USS Yorktown, USS Laffey, and Vietnam Experience, Patriots Point strives to preserve our naval history and the living history of our nation's bravest men and women while telling inclusive stories in honorable, educational, and engaging ways.

KEY OFFICIALS



ATTENDING

WAYNE ADAMS Acting Chairman
wadams@adamsgroup.com | 803.960.7624

ALLISON HUNT Agency Head
ahunt@patriotspoint.org | 843.881.5920

CHRIS HAUFF Chief of Staff
chauff@patriotspoint.org | 843.881.5984

NICK MAGAR Chief Financial Officer
nmagar@patriotspoint.org | 843.881.5996

PATRIOTS POINT DEVELOPMENT AUTHORITY BOARD

Wayne Adams, Acting Chairman

Susan Marlowe

Zeb Williams

G. Patton Waters

James Smith Jr.

Mayor Will Haynie, ex-officio, Town of Mt. Pleasant



ORGANIZATIONAL CHARTS

CHART 1

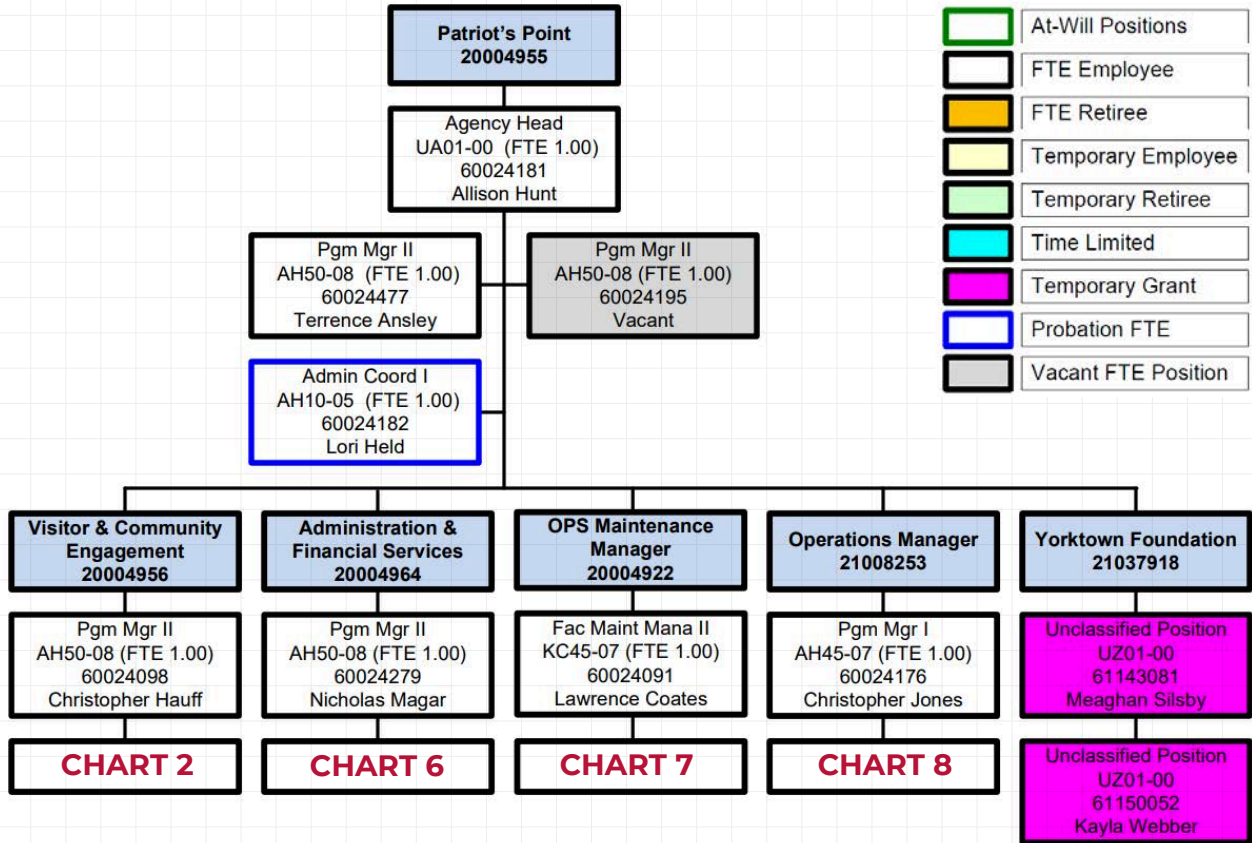



CHART 2

	At-Will Positions
	FTE Employee
	FTE Retiree
	Temporary Employee
	Temporary Retiree
	Time Limited
	Temporary Grant
	Probation FTE
	Vacant FTE Position

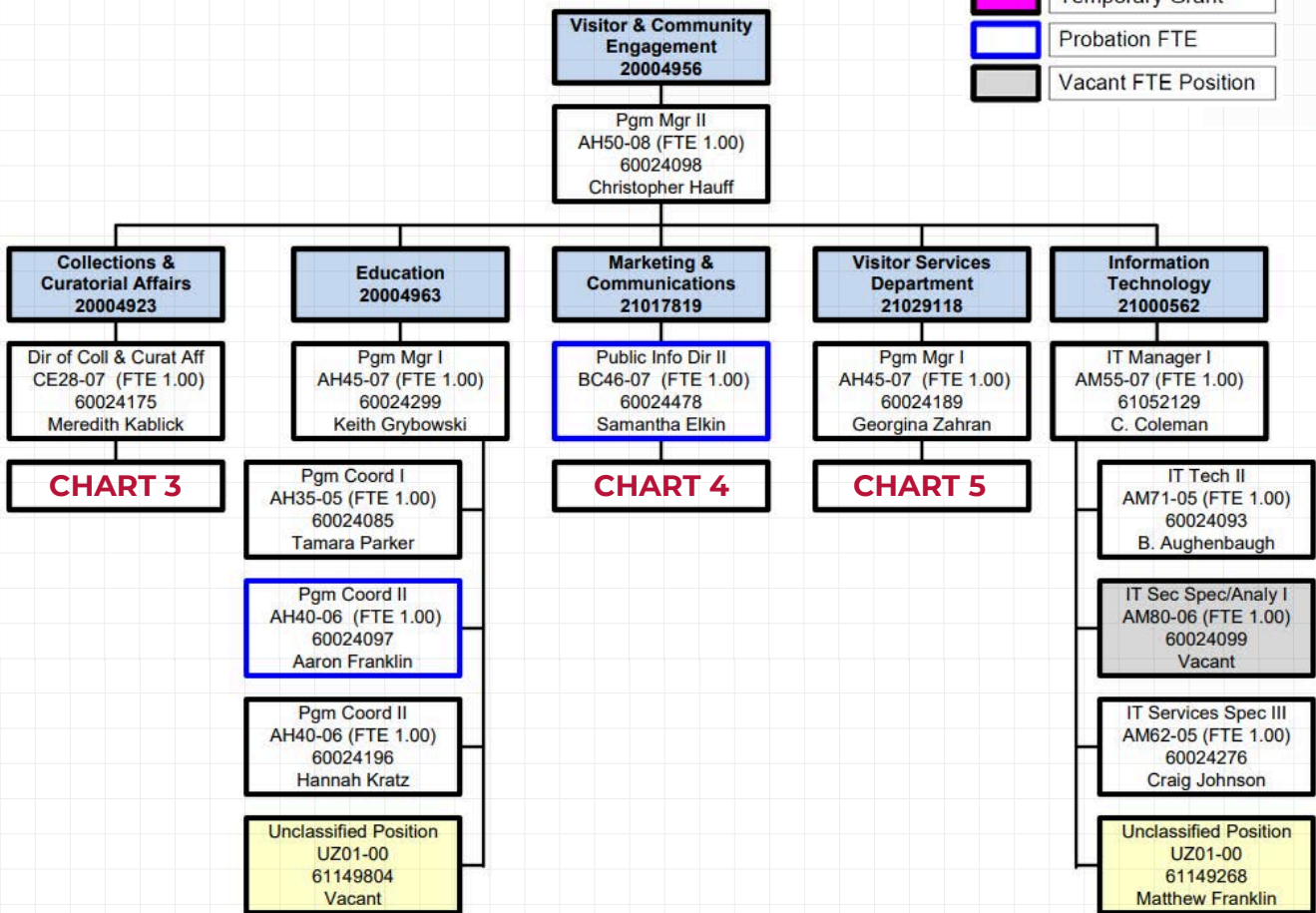

CHART 3

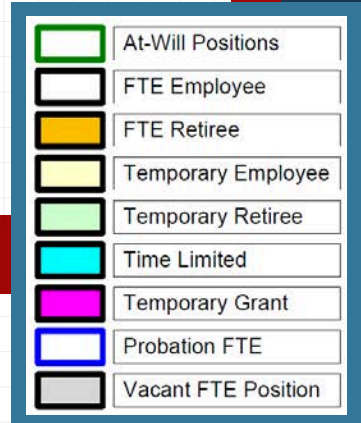
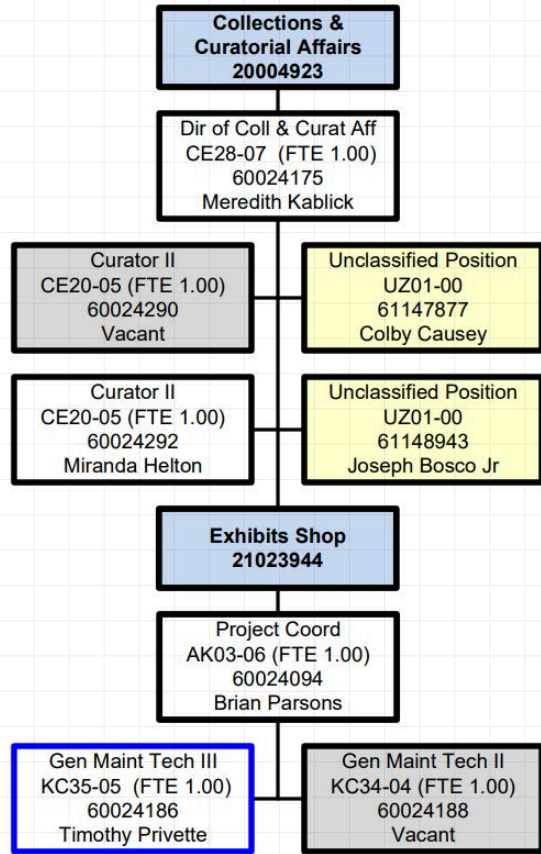

CHART 4

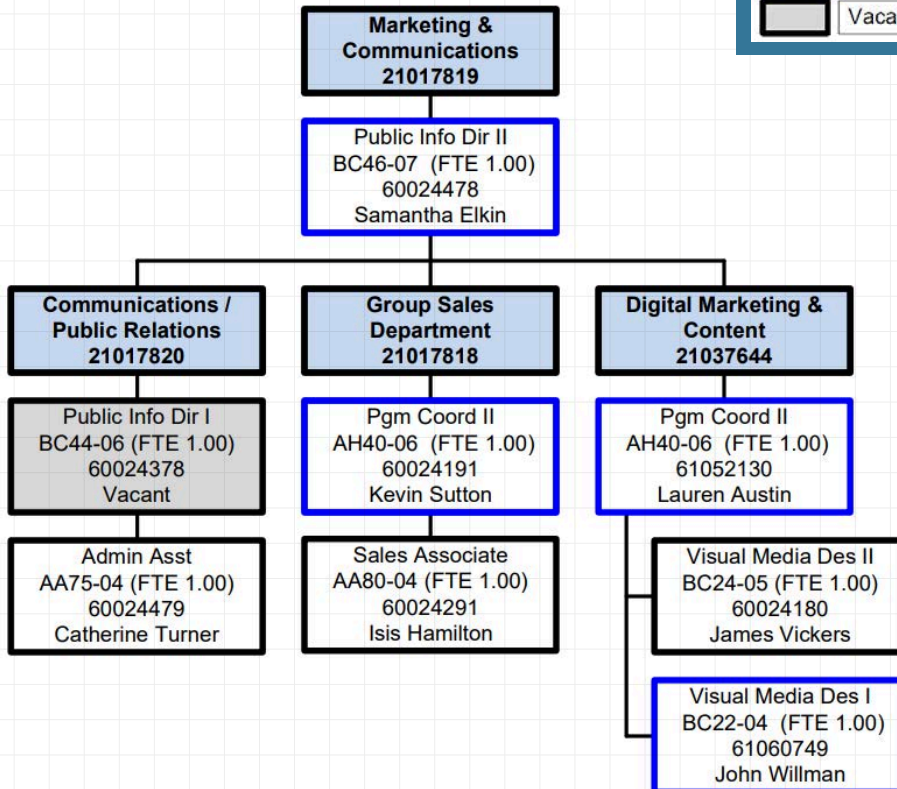



CHART 5

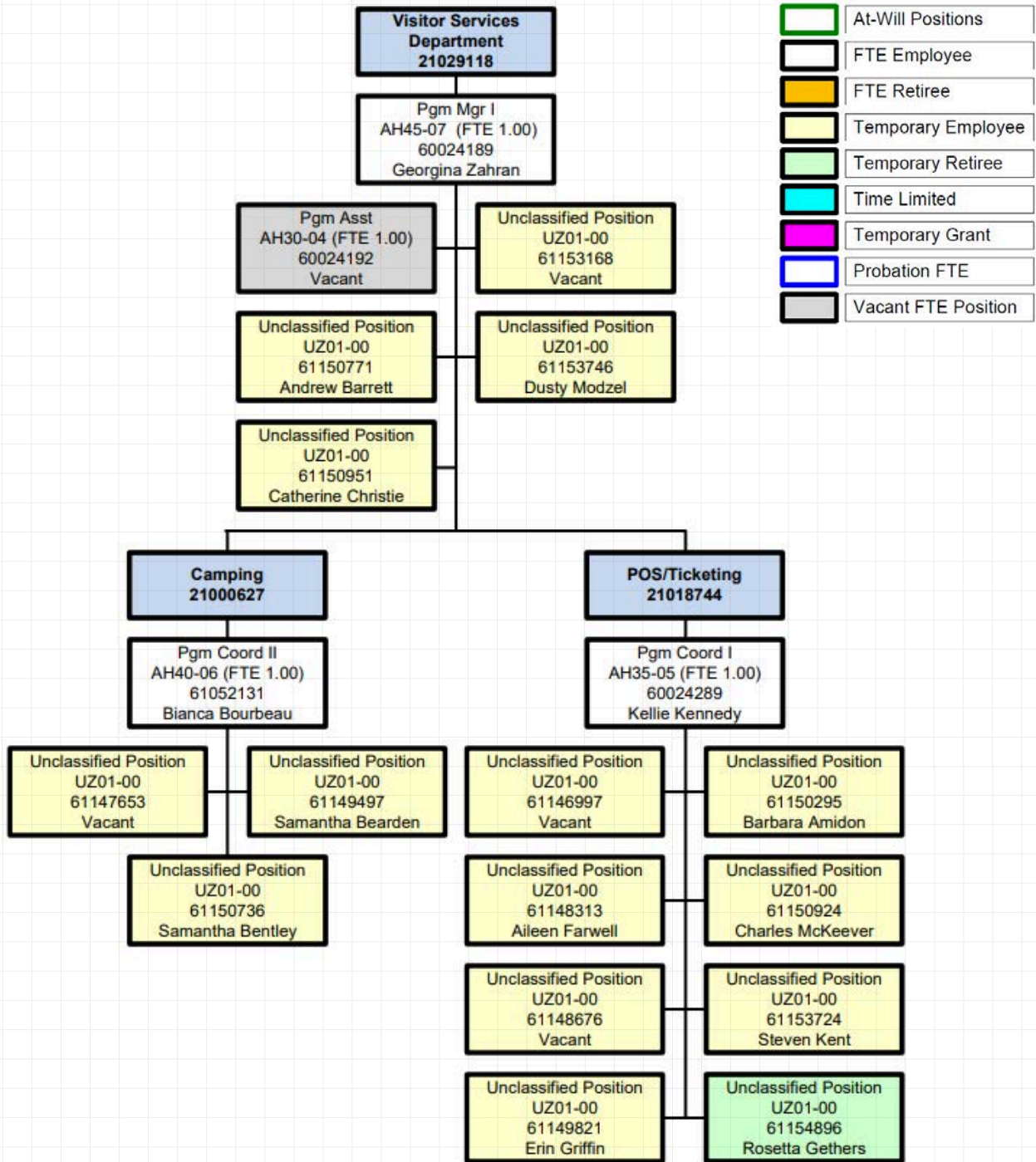
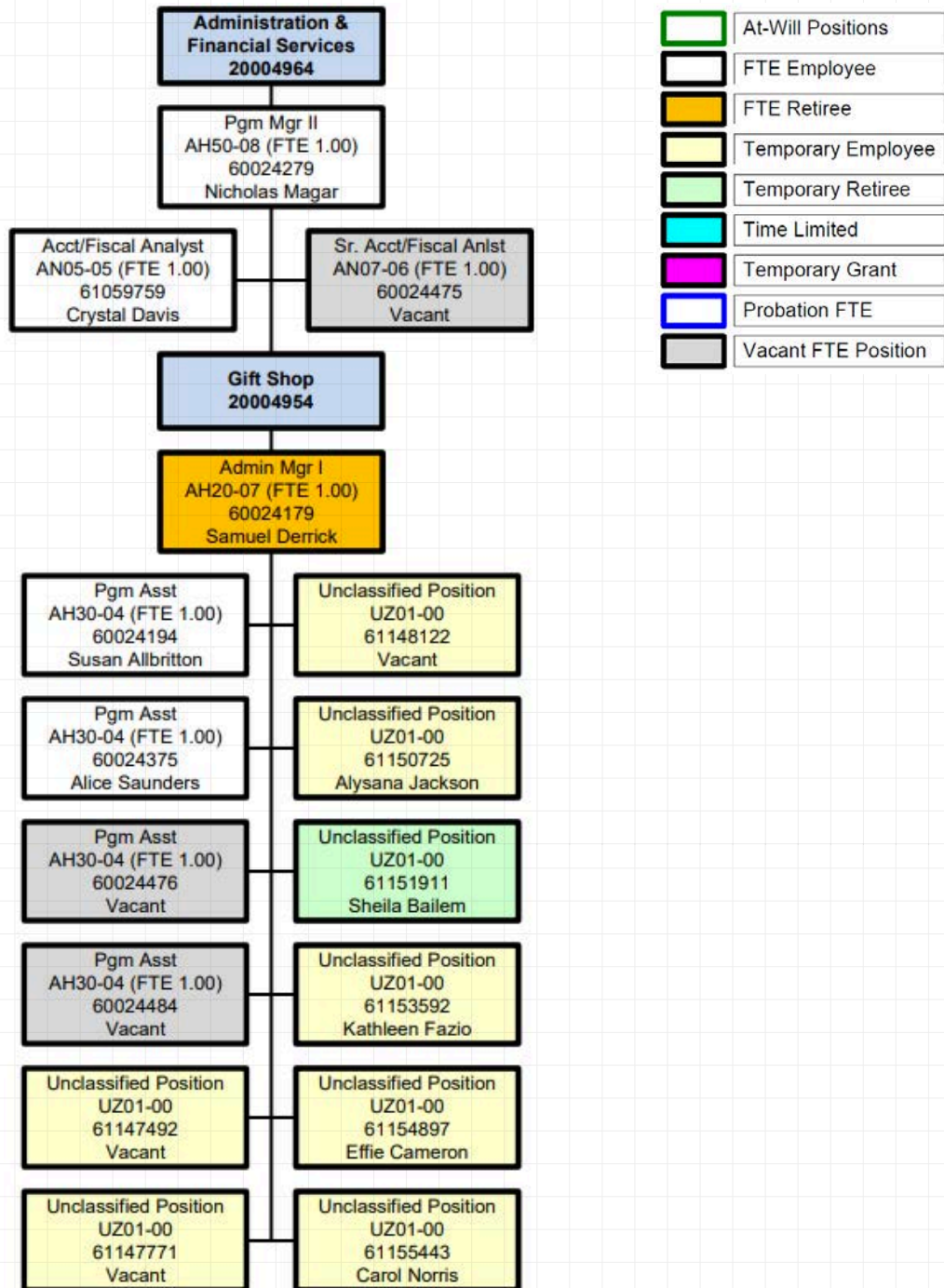



CHART 6



- At-Will Positions
- FTE Employee
- FTE Retiree
- Temporary Employee
- Temporary Retiree
- Time Limited
- Temporary Grant
- Probation FTE
- Vacant FTE Position





CHART 7

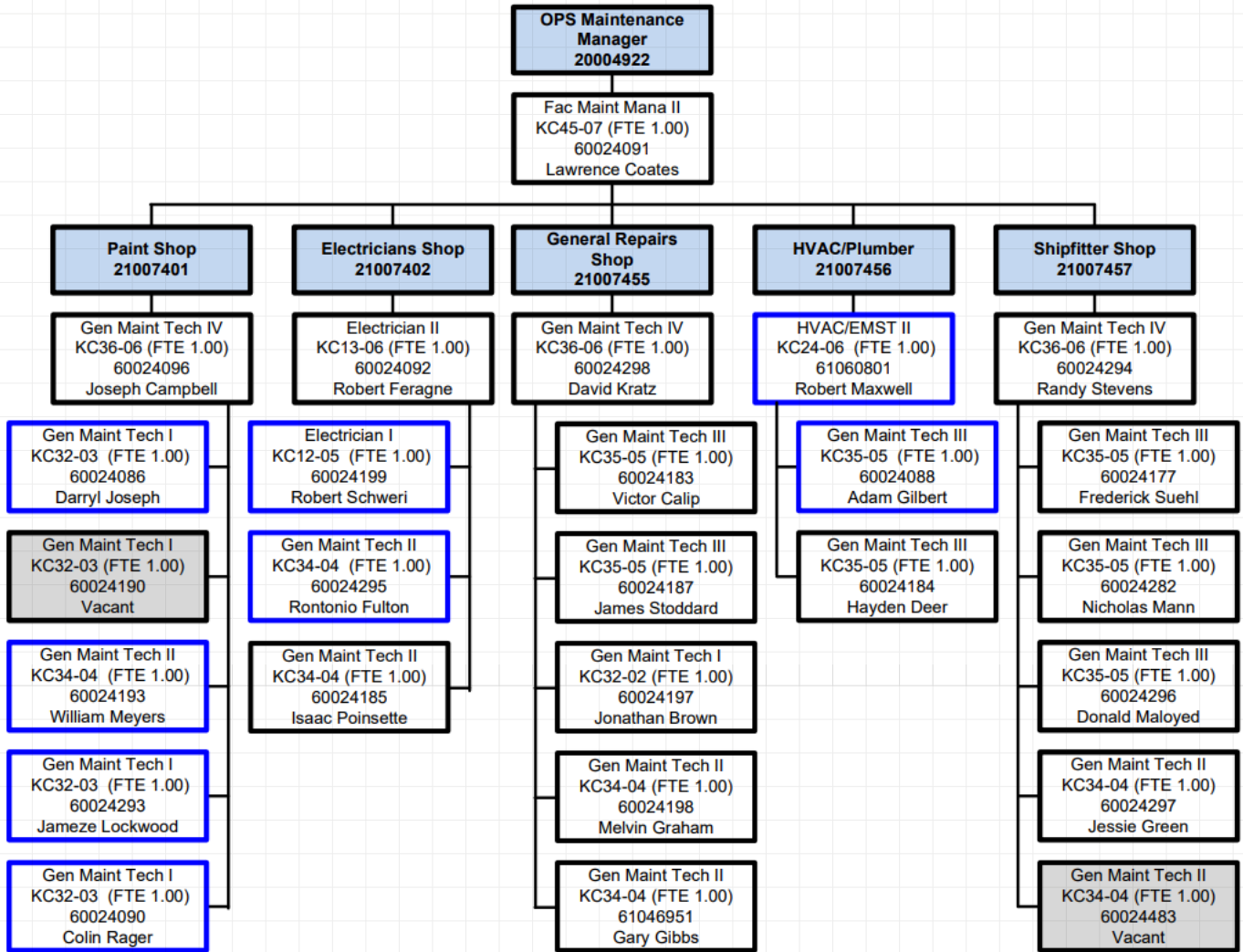

At-Will Positions	Temporary Employee	Temporary Grant
FTE Employee	Temporary Retiree	Probation FTE
FTE Retiree	Time Limited	Vacant FTE Position





CHART 8

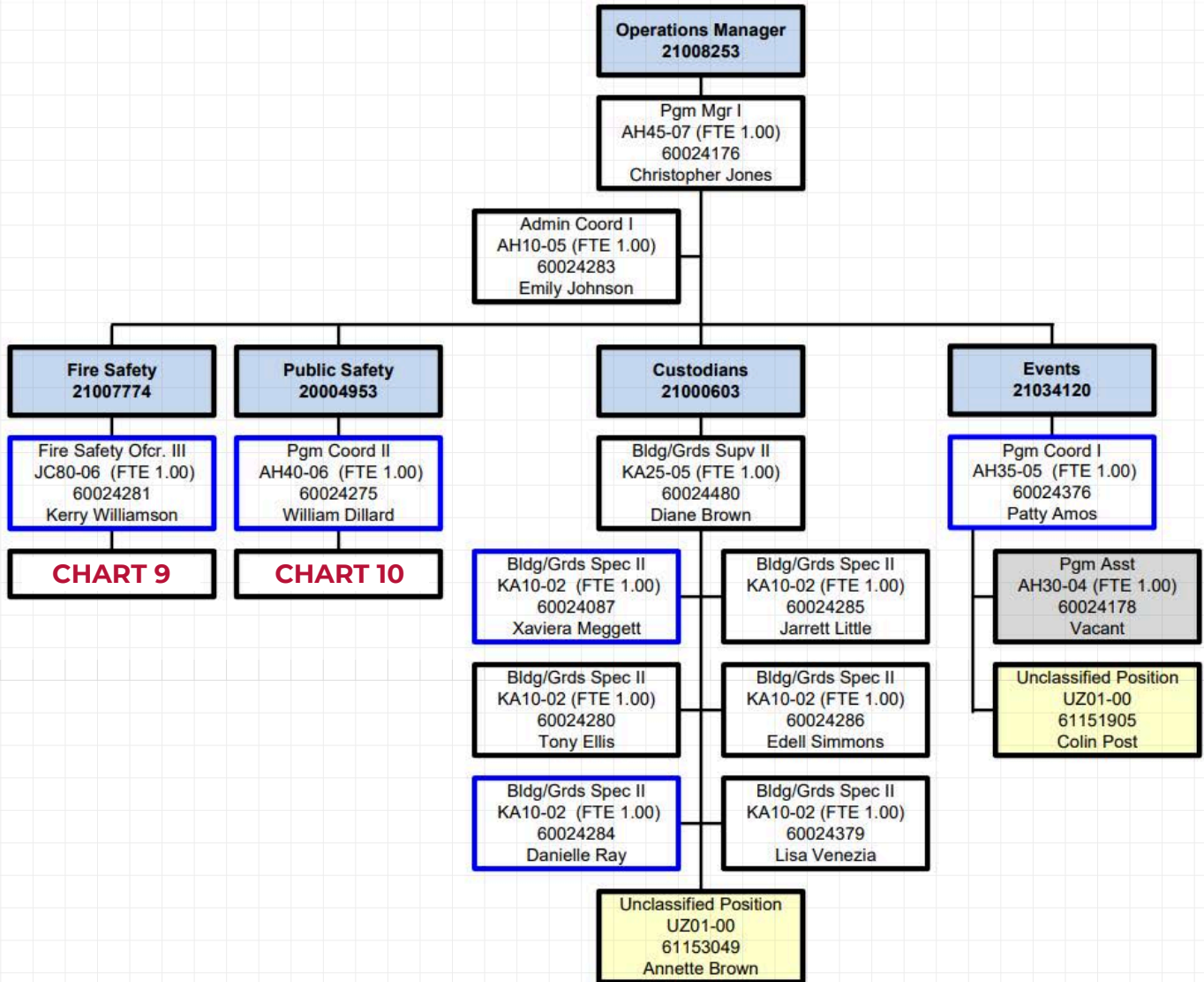

 At-Will Positions	 Temporary Employee	 Temporary Grant
 FTE Employee	 Temporary Retiree	 Probation FTE
 FTE Retiree	 Time Limited	 Vacant FTE Position





CHART 9

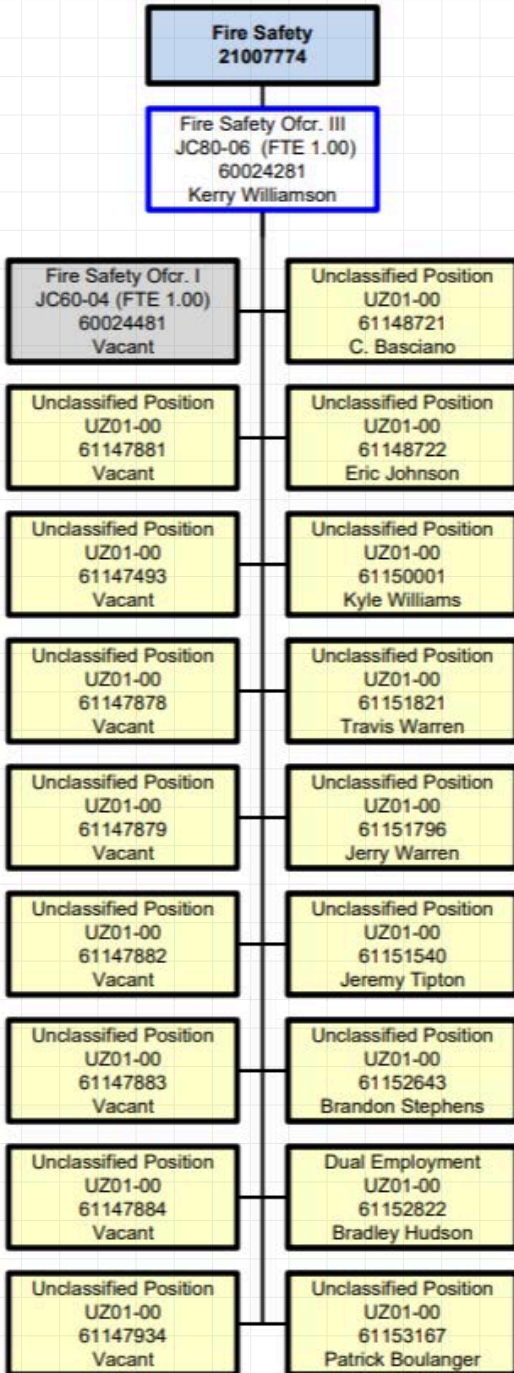
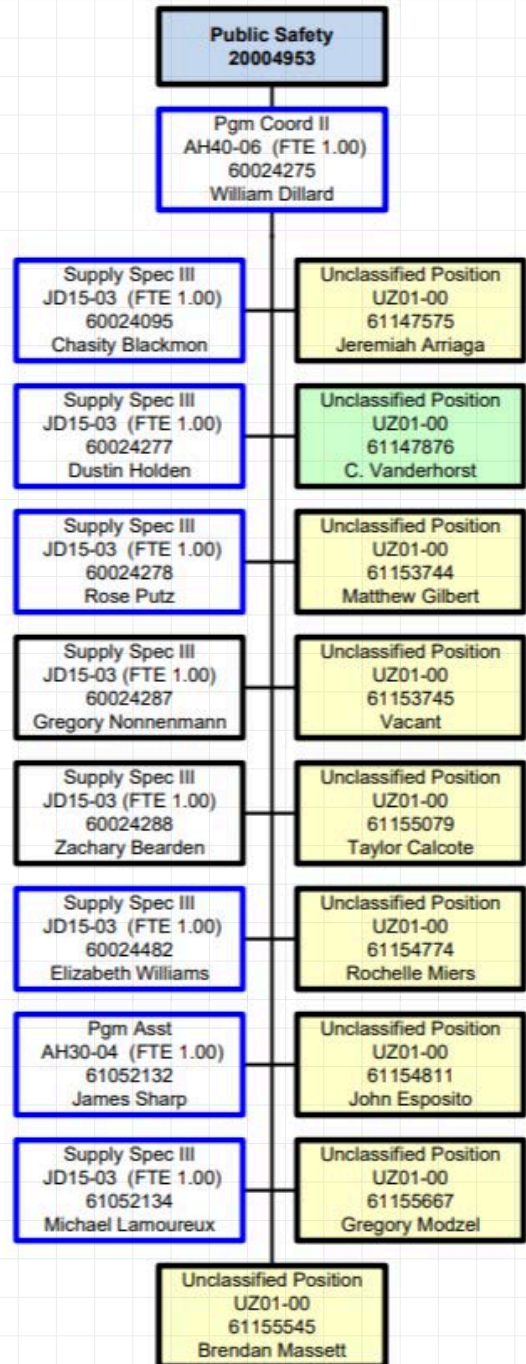

CHART 10



	At-Will Positions		Temporary Employee		Temporary Grant
	FTE Employee		Temporary Retiree		Probation FTE
	FTE Retiree		Time Limited		Vacant FTE Position

FY26 BUDGET & PROVISO REQUESTS

Patriots Point Development Authority has two budget requests and zero proviso requests or edits.

Priority Request 1: \$25,000,000 Capital Request of State Funds for a Landside Retail/Office Building and Structured Parking

Patriots Point Development Authority is in need of a landside facility to accommodate office, meeting, gift shop, exhibit, IT and data, public assembly and restroom uses. The agency has never had a permanent landside office building and employee offices were located in temporary mobile units. These leased temporary mobile units were removed in 2022 to make way for staff parking in light of other landside development. Office functions and staff were relocated to renovated spaces on board the USS Yorktown. Most of the office and meetings spaces onboard the USS Yorktown can not be made ADA compliant.

The current landside retail building and pavilion houses the agency's gift shop, ticketing services, public restrooms and other third-party vendors that operate onsite. This existing building will have to be removed to accommodate the Patriots Annex early phase of development. The current building was built in 1988. With notice at any time, the agency will have a maximum of 17 months to vacate the current building. The new building is needed to accommodate all of the agency's landside needs, be fully compliant with codes and ADA regulations for staff, board, and visitors and be fully accessible in all public spaces to guests and general public. Structured parking will be built below the new building in order to accommodate staff parking requirement.

The new Landside Retail and Office Building will house agency offices and meeting spaces, museum receiving/processing and display spaces, gift shop and ticketing spaces, food service spaces, public restrooms as well as office spaces for the various third party vendors that operate on the property.

Priority Request 2: \$5,000,000 Recurring Increase in Agency's Spend Authorization

The Patriots Point Development Authority's current state budget is \$15 million. The agency does not ask for yearly appropriations to fund annual operations. The revenue the agency generates through ticket admissions, as a lease tenant, and a few other sources funds the agency's annual operations. Patriots Point is asking to raise the amount of its own funds it can spend in a fiscal year from \$15 million to \$20 million. The increase of this authorization will allow the agency to make increased payments on its outstanding Laffey Loan, pay for the agency's portion of the USS Yorktown remediation project, and pay for the significant maintenance expenditures that need to be made in the coming years for the USS Yorktown, USS Laffey and the pier. The agency's current authorization level will not allow it to fund both its annual operations and these larger scale items. The agency is doing well enough to be able to fund these items without state funding, it just needs the authority to do so.

FY 25-26 Base Budget Summary

Budget vs Actual FY24

Major CI Name	Budget Act CI Info	Current Budget	YTD Actual Expense	Remaining Balance	Pct Spent
Personal Services	501014 EXECUTIVE DIR	\$ 131,232.28	\$ 131,232.28	\$ -	100%
	501058 CLASSIFIED POS	\$ 3,688,280.87	\$ 3,688,280.87	\$ -	100%
	501070 OTH PERS SVC	\$ 1,004,000.00	\$ 641,125.99	\$ 362,874.01	64%
Personal Services Total:		\$ 4,823,513.15	\$ 4,460,639.14	\$ 362,874.01	92%
Other Operating Expenses	512001 OTHER OPERATING	\$ 6,982,059.77	\$ 5,237,676.12	\$ 1,744,383.65	75%
Other Operating Expenses Total:		\$ 6,982,059.77	\$ 5,237,676.12	\$ 1,744,383.65	75%
Debt Service	508000 DEBT SERVICE	\$ 1,133,425.98	\$ 1,133,425.98	\$ -	100%
	508014 INT-LOAN NOTE	\$ 100,351.17	\$ 100,351.17	\$ -	100%
Debt Service Total:		\$ 1,233,777.15	\$ 1,233,777.15	\$ -	100%
		\$13,039,350.07	\$ 10,932,092.41	\$ 2,107,257.66	84%
Employer Contributions	513000 EMPLOYER CONTRIB	\$ 1,960,649.93	\$ 1,960,649.93	\$ -	100%
Employer Contributions Total:		\$ 1,960,649.93	\$ 1,960,649.93	\$ -	100%
		\$15,000,000.00	\$ 12,892,742.34	\$ 2,107,257.66	86%

Budget vs Actual FY25 (AS OF 1/3/2025)

Major CI Name	Budget Act CI Info	Current Budget	YTD Actual Expense	Remaining Balance	Pct Spent
Personal Services	501014 EXECUTIVE DIR	\$ 140,000.00	\$ 75,833.29	\$ 64,166.71	54%
	501058 CLASSIFIED POS	\$ 3,429,000.00	\$ 2,147,774.20	\$ 1,281,225.80	63%
	501070 OTH PERS SVC	\$ 1,004,000.00	\$ 459,889.75	\$ 544,110.25	46%
Personal Services Total:		\$ 4,573,000.00	\$ 2,683,497.24	\$ 1,889,502.76	59%
Other Operating Expenses	512001 OTHER OPERATING	\$ 7,010,000.00	\$ 2,445,945.32	\$ 4,564,054.68	35%
Other Operating Expenses Total:		\$ 7,010,000.00	\$ 2,445,945.32	\$ 4,564,054.68	35%
Debt Service	508000 DEBT SERVICE	\$ 1,564,166.24	\$ 1,564,166.24	\$ -	100%
	508014 INT-LOAN NOTE	\$ 102,833.76	\$ 102,833.76	\$ -	100%
Debt Service Total:		\$ 1,667,000.00	\$ 1,667,000.00	\$ -	100%
		\$13,250,000.00	\$ 6,796,442.56	\$ 6,453,557.44	51%
Employer Contributions	513000 EMPLOYER CONTRIB	\$ 1,750,000.00	\$ 1,183,166.67	\$ 566,833.33	68%
Employer Contributions Total:		\$ 1,750,000.00	\$ 1,183,166.67	\$ 566,833.33	68%
		\$15,000,000.00	\$ 7,979,609.23	\$ 7,020,390.77	53%





CARRY FORWARD CASH INFORMATION

Carry forward authority granted by Section 51-13-765 of the SC code of laws: The Patriots Paint Development Authority may maintain special accounts controlled by the authority and made up of funds received by the authority. The authority may retain and carry over these funds it has on account from fiscal year to fiscal year. The receipt and expenditure of funds in these accounts must be reported in an annual fiscal audit of the authority.

All earnings and interest accrued on accounts held by the authority must be retained and expended by the authority to carry out its purpose and mission.

FUND NUMBER	FUND TITLE	FISCAL YEAR 24 ENDING CASH BALANCE
30039000	AFS - Dual Employment	(76,341.68)
30267000	PR Liabilities SAP	(404.34)
30499000	AFS - Donations	4,177.58
31339000	AFS - ADM REV - EAR	20.93
36349000	AFS-CAP RES FD OPER	50,000.00
39079000	[CP] AFS - OTHER FDS	65,746.92
40499000	ADS - DONATIONS - Res	485,540.37
41339000	ADS - ADMISSIONS REV	15,551,091.02
49739000	AFS - EDUC IMP ACT 84	622,268.47

FTE BREAKDOWN

(AS OF 1/2/2025)

STATUS	STATE	FEDERAL	OTHER	TOTAL
FILLED	00	00	73	73
VACANT	00	00	13	13
TOTAL	00	00	86	86



THE MISSION

The primary mission of the Patriots Point Development Authority is two-fold. First, to establish, develop, and operate a national museum of ships, naval and maritime equipment, artifacts, books, manuscripts, art, and historical materials to foster patriotism, generate pride and respect for the U.S., and honor our valiant dead from World War II to the present.

Second, to develop and enhance the Patriots Point land area (approximately 460 acres) and water areas of the contiguous Cooper River to support the operation of ships, provide a place of education and recreation, and stimulate national and international travel by offering museums, attractions, lodging, and accommodation.

- 450,000 VISITORS
- 20,000 STUDENTS
- TWO SHIPS
- 28 AIRCRAFT
- VIETNAM EXPERIENCE

Walk in the steps of heroes

THE SHIPS

The USS YORKTOWN (CV-10) was the tenth aircraft carrier to serve the United States. YORKTOWN was commissioned on April 15, 1943. World War II's famous "Fighting Lady" would play a significant role in the Pacific offensive that began in late 1943 and ended with the defeat of Japan in 1945.

In the 1950s, YORKTOWN was modernized to operate jet aircraft as an attack carrier (CVA). In 1957, she was re-designated as an anti-submarine aircraft carrier. YORKTOWN was decommissioned in 1970 and became the centerpiece of Patriots Point Naval & Maritime Museum in 1975.



USS Yorktown (CV-10)



USS Laffey (DD-724)

The USS Laffey (DD-724) was commissioned on February 8, 1944. LAFFEY supported the D-Day landings at Normandy and participated in the U.S. offensive against Japan. While operating off Okinawa, she was attacked and hit by 22 Japanese bombers and kamikaze. Her crew's heroic actions earned her the nickname: "The Ship That Would Not Die." In the 1950s, LAFFEY was recommissioned to serve in the Korean and Cold Wars. She joined the Patriots Point fleet in 1981.

THAT INSPIRE



> EDUCATION & DISTANCE LEARNING

Supports the education of SC students in alignment with the Profile of the SC Graduate by emphasizing learning in content areas, supporting struggling students, improving teacher quality, and improving connections across K-12 education, career, and post-secondary. Through support from the Education Improvement Act, students and teachers across the state have access to Patriots Point programming. Patriots Point also hosts an annual two-day Teacher Recertification Professional Development Program.



> FLIGHT ACADEMY

Whether planning the mission from the Joint Intelligence Center, controlling the traffic flow and advising pilots from the Joint Operations Center, or piloting from the Hangar Bay, students perform various tasks and succeed at many different challenges. This program engages their teamwork and communications skills to learn and practice fundamental aeronautics, history, math, and science.



> COMMUNITY EVENTS

It could be veterans painting with renowned artist Mary Whyte to escape symptoms of post-traumatic stress, or 500 people climbing aboard the Yorktown to remember those that paid the ultimate price on Pearl Harbor Day, free community events on days such as Vietnam War Veterans Day, Pearl Harbor Day, Medal of Honor Day, and Veterans Day have made Patriots Point a destination for Patriotism.



> OPERATION OVERNIGHT

Program participants walk among some of our military's most notable airplanes and ships during their adventure while learning what life was like for Navy sailors. They sleep in traditional Navy berthing compartments and eat meals in one of the ship's many galleys. While aboard, they hear stories of heroism and experience the WWII aircraft carrier like no other as they go behind the scenes to Live Like a Sailor.



> VOLUNTEERS

More than 120 volunteers, many of whom are veterans, serve as the heartbeat of the museum. Being a volunteer means making new friends, personal satisfaction, and teamwork. In addition to daily hospitality duties, volunteers proudly support the Patriots Point Veterans History Project and the Enrichment Program (VEP). VEP is a speaker series that features volunteers who share experiences or subject matter knowledge.

> VIETNAM EXPERIENCE

The 2.5-acre Vietnam Experience brings the history of the Vietnam War to life through replicas of a U.S. Naval Support Base in South Vietnam and a Marine combat base modeled after Khe Sanh. The Vietnam Experience also serves as a place for the two million Vietnam veterans in the United States to reflect and reconnect with their experiences during their years of service and for the treatment of PTSD by the Ralph Johnson VA Medical Center.



DESTINATION PATRIOTS POINT



CHARLESTON HARBOR RESORT & MARINA



SPIRITLINE CRUISES



COLLEGE OF CHARLESTON ATHLETICS



THE COTTAGES ON CHARLESTON HARBOR

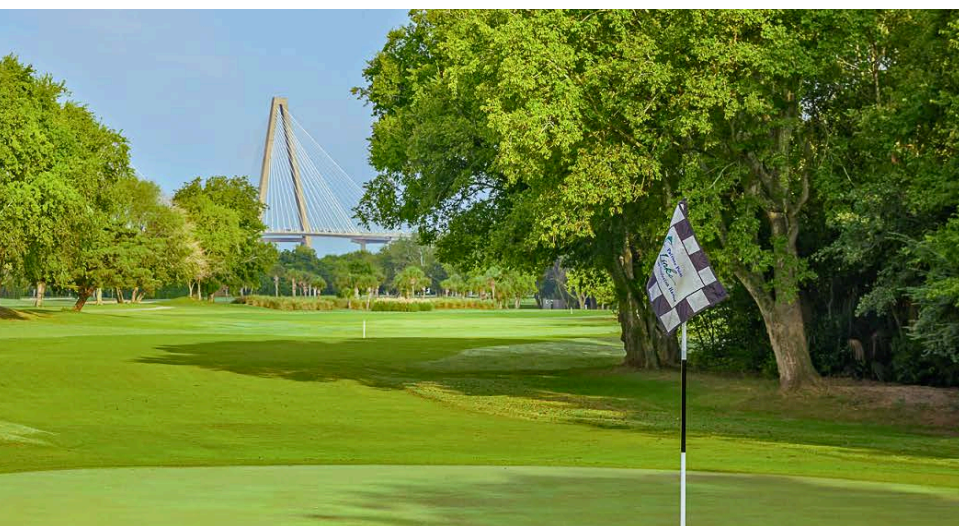

PATRIOTS POINT LINKS



CHARLESTON BATTERY

PATRIOTS POINT
NAVAL & MARITIME
MUSEUM

THANK YOU!

